

Embedded Control Project

Precisely Controlled DIY Etching Machine For Usage at Home
and in Small Labs

Nils Weber and Maximilian Stiefel

November 15, 2017

Uppsala University

Table Of Contents

1. System Requirements
2. State of the Art

System Requirements

What do we want to achieve?

- UV light with 256 LEDs (approx. 30 W)

What do we want to achieve?

- UV light with 256 LEDs (approx. 30 W)
- Heater for Etching bath

What do we want to achieve?

- UV light with 256 LEDs (approx. 30 W)
- Heater for Etching bath
- Neat user interface (rotary knobs, tactile switches and OLED)

What do we want to achieve?

- UV light with 256 LEDs (approx. 30 W)
- Heater for Etching bath
- Neat user interface (rotary knobs, tactile switches and OLED)
- Smart, small, intuitive to use

System Overview

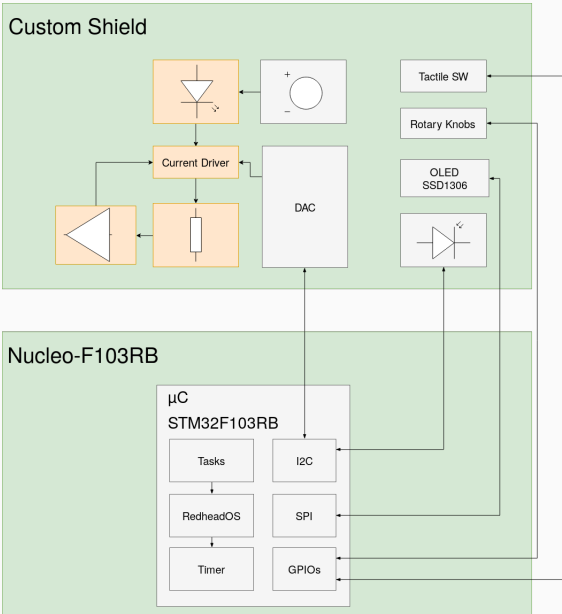

State of the Art

- ARM-based 32 bit processor

State of the Art

- ARM-based 32 bit processor
- Self-designed current source

State of the Art

- ARM-based 32 bit processor
- Self-designed current source
- SW-based controllers for aging effects compensation

State of the Art

- ARM-based 32 bit processor
- Self-designed current source
- SW-based controllers for aging effects compensation
- SW-based controllers for temperature regulation

Happy Coding :)